



**MITSUBISHI ELECTRIC AUTOMATION (THAILAND) CO., LTD.**  
 Bang-Chan Industrial Estate No. 111 Moo 4, Serithai Rd., T.Kannayao, A.Kannayao, BKK 10230 Thailand  
 Tel: (66) 2517-1326, (66) 2919-9873 Fax: (66) 2517-1328 URL: www.meath-co.com E-mail: support@meath.co.th  
**บริษัท มิตซูบิชิ อิเล็กทริก ออโตเมชัน (ประเทศไทย) จำกัด**  
 นครอุตสาหกรรมบางชัน เลขที่ 111 หมู่ 4 ถนนเสรีไทย แขวงคันนายาว เขตคันนายาว กทม. 10230  
 โทรศัพท์: (66) 2517-1326, (66) 2919-9873 โทรสาร: (66) 2517-1328 URL: www.meath-co.com E-mail: support@meath.co.th

**MOTOR SPECIFICATION SHEET**

MODEL : SF-PRO 22kW 4P  
 USED FOR : 380V 50Hz  
 MANUFACTURER : MITSUBISHI ELECTRIC CORPORATION

DESCRIPTION	DETAIL
PHASE	3
MODEL NAME	SF-PRO
RATED OUTPUT	22 kW
POLE	4
CODE	MEATH CODE : 1MU00F-402200LJLT0
OUTLINE DRAWING NO.	BD39194-*
RATED VOLTAGE (V)	380
RATED FREQUENCY (Hz)	50
RATED CURRENT (A)	42
RATED SPEED (min <sup>-1</sup> )	1475
RATED EFFICIENCY	93.7%
EFFICIENCY CLASS	IE3
THERMAL CLASS	130 (B)
RATING	S1 (CONTINUOUS)
ENCLOSURE CONSTRUCTION	TOTALLY ENCLOSED FAN COOLED
DEGREES OF PROTECTION	IP44 (OUTDOOR WATERPROOF)
METHOD OF COOLING	IC411
FRAME NO.	180M
WEIGHT (kg)	155
STANDARD	JIS C 4213, JEC-2137-2000
INSTALLATION	FOOT MOUNTED
ROTATION	CCW (VIEWED FROM SHAFT END)
BEARING	LOAD SIDE : 6311ZZ
	OPPOSITE SIDE : 6310ZZ
BEARING GREASE	UREA GREASE
NOISE (dB.A)*	66
VIBRATION	V15
CIRCUMSTANCE CONDITION	AMBIENT TEMPERATURE : -30 ~ +40°C
	AMBIENT HUMIDITY : 100% RH (NO CONDENSATION)
	ABOVE SEA LEVEL : 1000m OR BELOW
	ENVIRONMENT : NO CORROSIVE/EXPLOSIVE GAS, NO STEAM OR CONDENSATION, MINIMAL DUST.
COLOR	MUNSELL N7 (GRAY)
TERMINAL BOX	NO. OF LEAD WIRES : 6
	SOURCE CONNECTION : LEAD WIRES
SHAFT SWING	≤0.05mm
MATERIAL	FRAME : STEEL PLATE
	BRACKET : ALUMINIUM
	SHAFT : CARBON STEEL
	STATOR CORE : ELECTRICAL STEEL
	WIRE : ENAMELLED COPPER MAGNET WIRE
	ROTOR CORE : ELECTRICAL STEEL
	CONDUCTOR : ALUMINIUM
	TERMINAL BOX : STEEL PLATE
PAINING : POLYURETHANE RESIN	
PRODUCTION COUNTRY	JAPAN

\*Value indicates representative value, not guaranteed value.

Specifications subject to change without notice.

<b>SPECIFICATION SHEET NO.</b>				
SS-M-3613-B				

# TYPE SF-PRO SUPER-LINE THREE PHASE INDUCTION MOTOR

OUT LINE  
DIMENSION IN mm

OUTDOOR USE TYPE

TOTALLY ENCLOSED FAN COOLED  
PROTECTION DEGREE IP44 , COOLING METHOD IC411  
FRAME NO. 180M

CUSTOMER \_\_\_\_\_  
USER \_\_\_\_\_  
FOR \_\_\_\_\_  
CUST' S ORDER NO. \_\_\_\_\_  
QUANTITY \_\_\_\_\_ UNIT (S) \_\_\_\_\_  
MFG ORDER NO. \_\_\_\_\_

YOUR ORDER	kW · POLES	VOLT	HERTZ	MASS kg/UNIT	STYLE NO.
	22 kW 4P	380V	50Hz	155	

IE Code-Rated Eff	
22kW 4P	IE3-93.7%

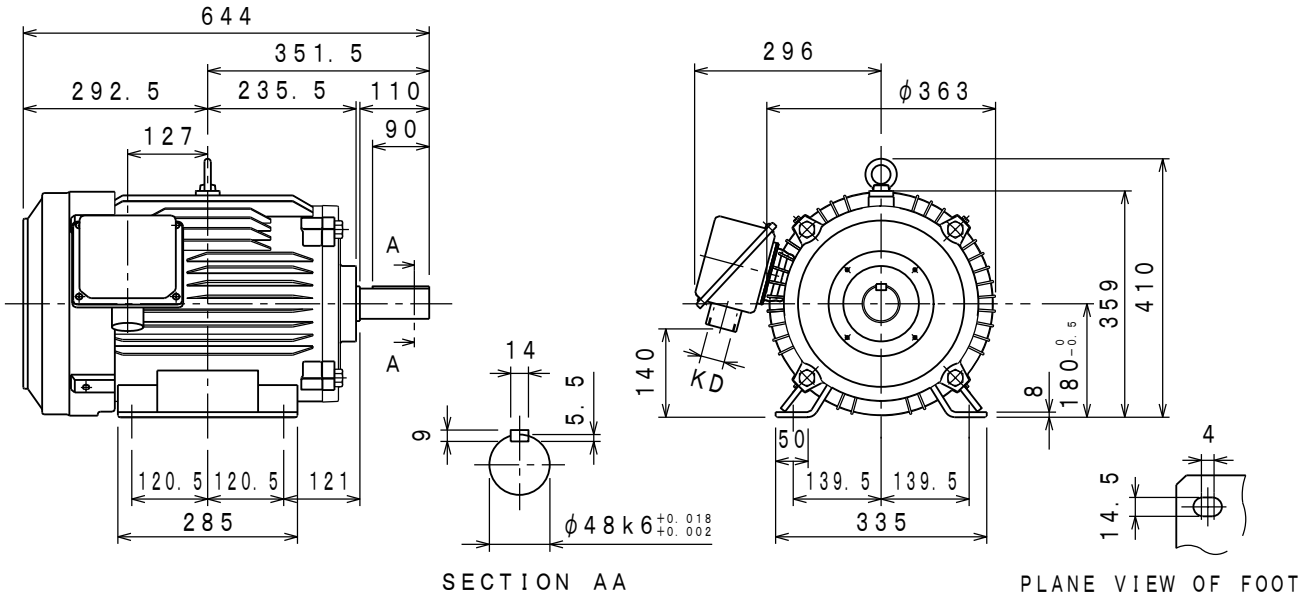

RATING	TH. CLASS	AMB. TEMP	BEARINGS		NO. OF TERMINALS	VIEWED FROM DRIVE END		COLOUR	KD
			LOAD SIDE	OPPOSITE SIDE		DIRECT. OF TERMINAL BOX	ROTATION		
S1	130 (B)	40° C	6311ZZ	6310ZZ	6	A (LEFT)	CCW	MUNSELL N7	PF1 1/2 SCREW

	DRAWN	APPROVED
SCALE NTS		
DATE FEB. 15. '19		

(和文: BD27109)

MITSUBISHI ELECTRIC CORP., JAPAN  
NAGOYA WORKS

CHANGE			

図面  
番号  
NO. **BD39194-\***

CAD(2D)